

Standard range of internal optical components and an external KF25 based sensor

gencoa: perfect your process

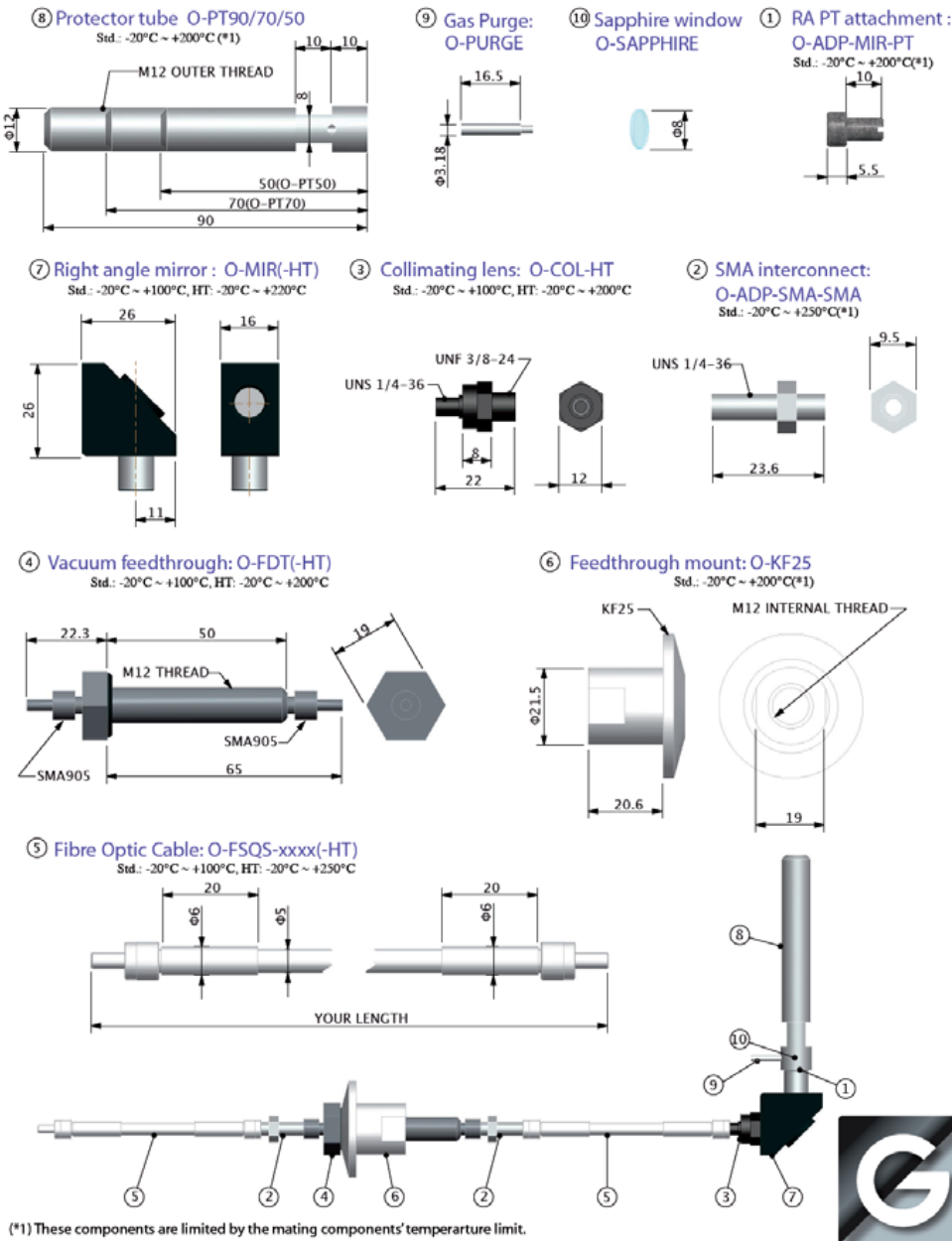

(*1) These components are limited by the mating components' temperature limit.

